

C.L-CNC-005

CNC全自动内圈机

CNC Automatic acetate inner cutting machine

功能

胶架车内圈专用机

Functions

Automatic acetate inner cutting.

优点

- 全自动上料，无需人工操作
- 灵活方便，实用性强，加工速度快
- 光洁度好，精度高

Advantages

- Fully automatic feeding, no personnel operation.
- Flexible and convenient, practical, fast processing speed.
- The finish is good and accurate.

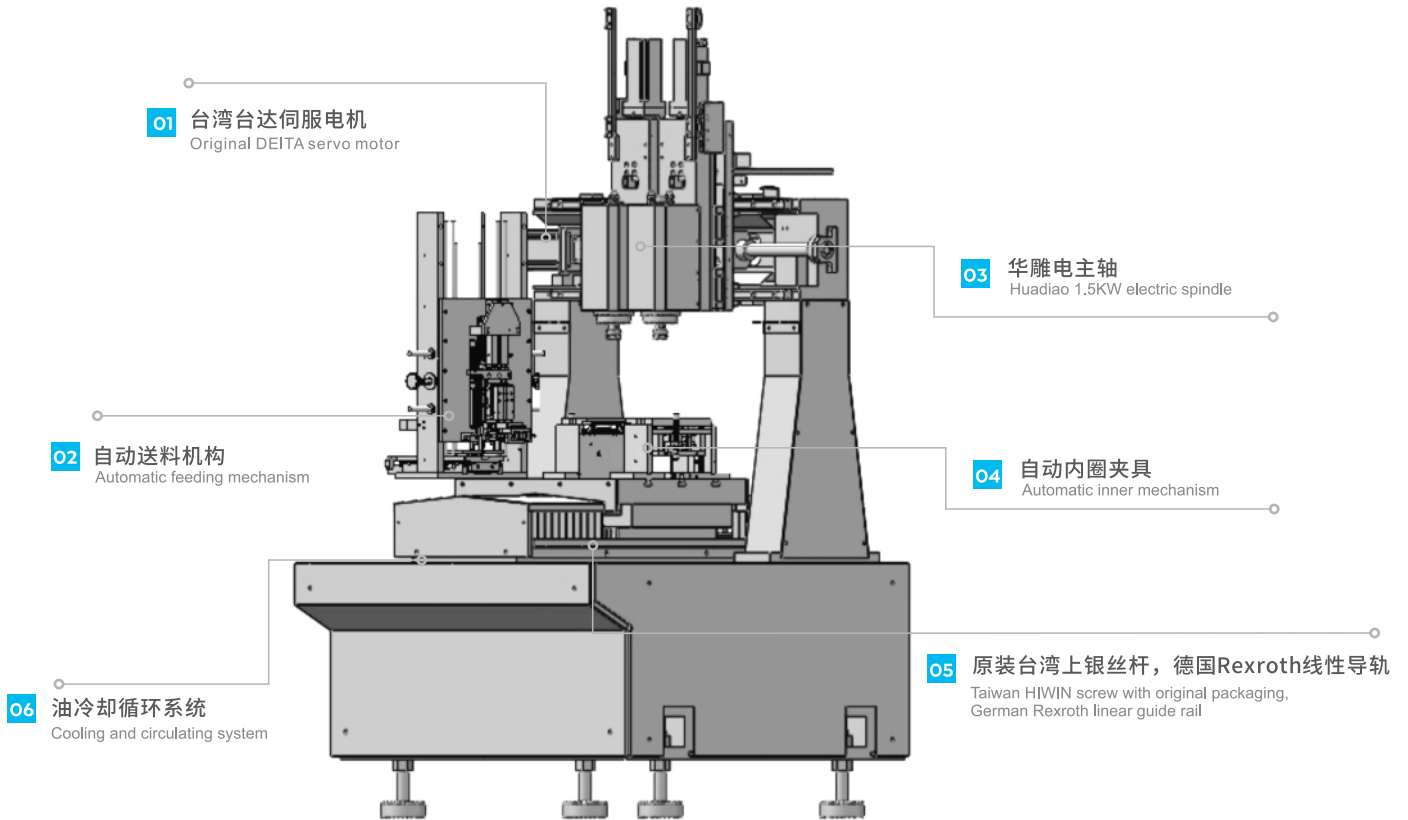

技术参数 / Technical Parameters

性能指标项 Performance index	标准值 standard value	刀具规格 Shank mode	ER16
X、Y、Z轴运动定位精度 Positional accuracy of X/Y/Z axes movement	0.015mm	快速移动速度 Rapid feed rate	20m/min
X、Y、Z轴工作行程 Operating stroke of X/Y/Z axes	400mm*300mm*150mm	工作电压 Working voltage	220V/50HZ
工作台尺寸 Table size	450mm*380mm	驱动系统 Driving system	交流伺服 Alternating current servo
主轴功率 Spindle power	1.5KW	操作系统 Operating system	新代系统+手执盒 SYNTEC system +hand box
主轴转速 Spindle speed	3000-24000RMP	气源压力 Air pressure	0.6MPA
机床尺寸 Machine dimension	1200*1250*1850	床体重量 Machine tool weight	1550KG